

wiltshire®

BAR·B·

GAS



BOSS 4 BURNER GAS BARBECUE - OWNERS MANUAL

Retain manual for future reference

BOSS 4 BURNER GAS BARBECUE - OWNERS MANUAL







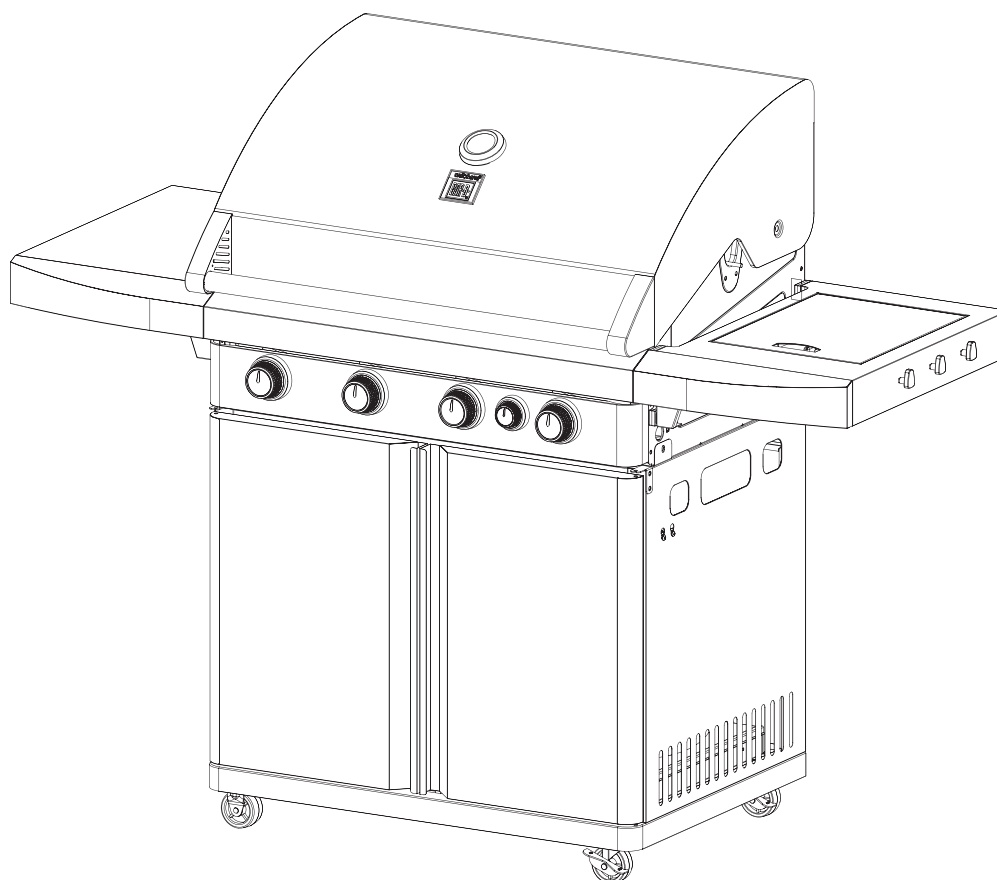



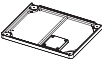











We'd like to thank you for choosing a Wiltshire BAR-B gas barbecue. We believe that our barbecue will provide you with the many years of reliable service that you have come to expect of anything with the Wiltshire name on it. Please take the time to read these instructions thoroughly before use. These will not only help you get the most from your new barbecue, but will ensure that you use the barbecue safely. If you have any questions or suggestions, please contact us. You will find the details on the back of this manual.

INDEX







Parts list	2	Teppanyaki	12
Setting up the Barbeque	3	Wok	12
Assembly instructions	4	Cleaning	12
Safety	10	Regular cleaning	12
Leak Test	11	Maintenance	13
Igniting	12	Checks & repairs	13
Cooking	12	Trouble shooting	13
Before the first use	12	Accessories	13
Grilling	12	Warranty	14
Roasting	12	Contact	15

















PARTS LIST

	ITEM DESCRIPTION	QUANTITY	PICTURE
1	CART BOTTOM PLATE ASSEMBLY	1	
2	RIGID CASTER	2	
3	SWIVEL CASTER	2	
4	CART LEFT PANEL WELD	1	
5	CART RIGHT PANEL WELD	1	
6	CART REAR PANEL	1	
7	GAS TANK TRAY	1	
8	MAGNET	1	
9	BASKET	2	
10	DOOR UPPER	1	
11	DOOR ASSEMBLY	2	
12	BODY & LID ASSEMBLY	1	
13	LEFT SHELF ASSEMBLY	1	
14	RIGHT SHELF ASSEMBLY	1	
15	SIDE SPACER FRONT	2	
16	SIDE SPACER REAR	2	
17	SIDE GRILL	1	
18	SIDE BURNER & DISH	1	
19	WARMING RACK	1	
20	COOKING GRID	2	
21	COOKING PLATE	1	
22	HEAT PANEL	2	

PARTS LIST

	ITEM DESCRIPTION	QUANTITY	PICTURE
23	OIL CUP	1	
24	FLEXIBLE GAS HOSE FIXED	1	
25	BASKET VERTICAL SUPPORT	2	
26	BASKET HORIZONTAL SUPPORT	4	
27	DOOR AXIS SUPPORT-L	1	
28	DOOR AXIS SUPPORT-R	1	

FASTENERS

	ITEM DESCRIPTION	QUANTITY	PICTURE
A	M6X12MM PHILIPS HEAD SCREW	50	
B	M6 SPRING WASHER	58	
C	M6 FLAT WASHER	58	
D	M6X45MM PHILIPS HEAD SCREW	4	
E	M6X25MM PHILIPS HEAD SCREW	8	
F	M4X10MM PHILIPS HEAD SCREW	4	
G	M4 SPRING WASHER	4	
H	M4 FLAT WASHER	4	
I	M4 MICA WASHER	4	
J	M4 NUT	4	
K	M3X10MM PHILIPS HEAD SCREW	2	
L	M3 NUT	2	
	SPANNER	1	
	SCREWDRIVER	1	

SETTING UP THE BARBEQUE

THIS APPLIANCE SHALL ONLY BE USED IN AN ABOVE GROUND OPEN AIR SITUATION WITH NATURAL VENTILATION, WITHOUT STAGNANT AREAS, WHERE GAS LEAKAGE AND PRODUCTS OF COMBUSTION ARE RAPIDLY DISPERSED BY WIND AND NATURAL CONVECTION

1. POSITIONING

- Please make sure that the barbeque is NOT positioned underneath any combustible material or surface.
- There MUST be a clearance of at least 250mm from the sides of the Barbeque to any combustible materials or surfaces. There must also be a clearance of at least 1500mm above the cooking surfaces to any combustible surface, and 500mm clearance at the back.
- Flammable materials of any description MUST be kept well away from the barbeque.
- The barbeque must be positioned such that the gas cylinder is kept away from direct sunlight.
- The barbeque must be positioned to avoid walkways, gangways and general pedestrian access.
- The nature of a barbeque is such that many of the surfaces are hot to touch, the positioning of the barbeque should take into consideration the possibility of accidental hand or body contact.

Any enclosure in which the appliance is used shall comply with one of the following:

- An enclosure with walls on all sides, but at least one permanent opening at ground level and no overhead cover.

SEE EXAMPLE 1

- Within a partial enclosure that includes an overhead cover and no more than two walls.

SEE EXAMPLE 2 & 3

- Within a partial enclosure that includes an overhead cover and more than two walls, the following shall apply-
 - at least 25% of the total wall area is completely open; and
 - at least 30% of the remaining wall area is open and unrestricted

SEE EXAMPLE 4 & 5

- In the case of balconies, at least 20% of the total of the side, back and front wall areas shall be and remain open and unrestricted

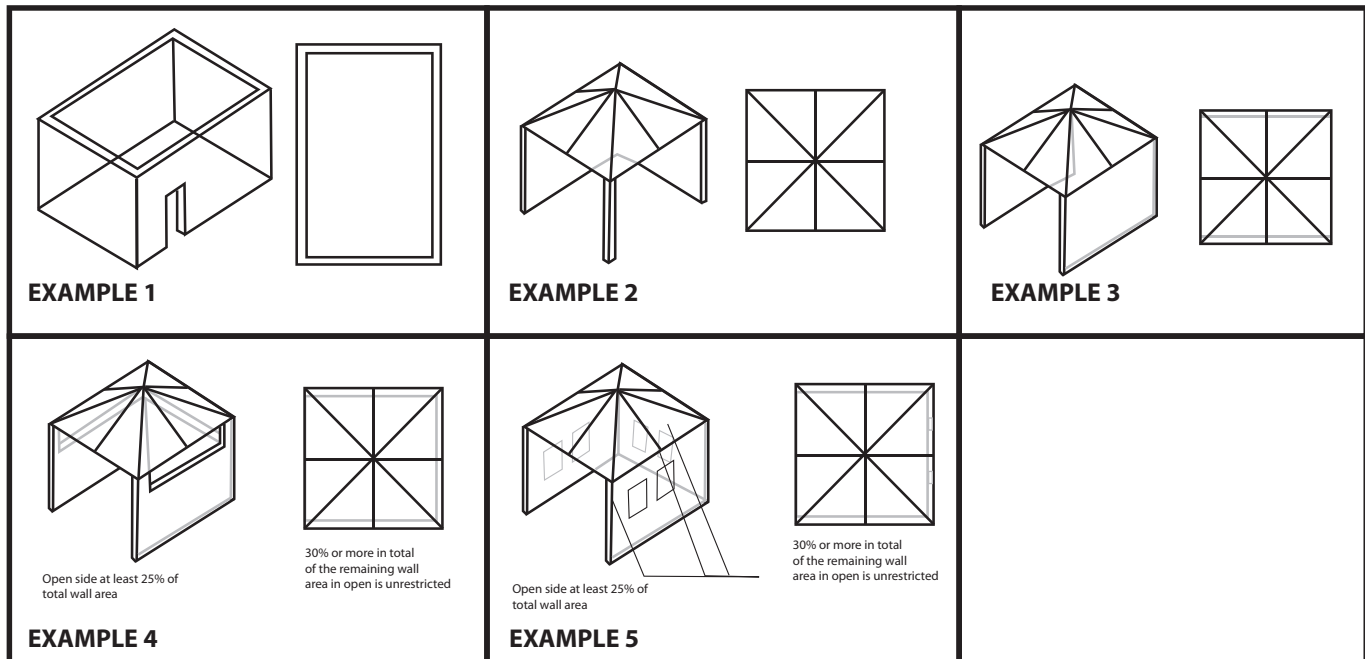

ASSEMBLY & INSTALLATION

PLEASE ENSURE THAT YOU HAVE ALL PARTS AND FASTENERS BEFORE BEGINNING ASSEMBLY.

STEP 1

ATTACH CASTERS

1. Turn Cart Bottom Plate Assembly (1) upside down.
2. Align each caster on each of the cart bottom caster plates, as shown in diagram.
3. Thread 4xBolt (A) first with Spring Washer (B) and then Flat Washer (C).
4. Screw through the caster hole into the cart bottom caster plates.
5. Repeat for each caster making sure Rigid Casters (2) are on the left-hand side and the Swivel Castors (3) are on the right-hand side of cabinet.

A M6X12...16 PCS



B M6 SPRING WASHER...16 PCS



C M6 FLAT WASHER...16 PCS

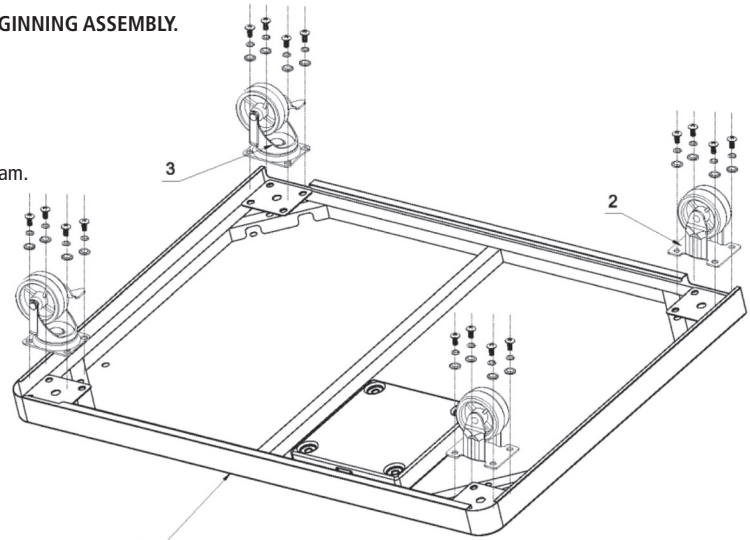

STEP 2

ATTACH LEFT AND RIGHT PANELS

1. Both rounded corners of Cart Bottom Plate Assembly (1) should be facing the front of cabinet as shown in diagram.
2. Align the Cart Left Panel (4) pre-drilled holes to Cart Bottom Plate Assembly (1).
3. Thread 3xBolt (A) first with Spring Washer (B) and then Flat Washer (C).
4. Screw through Cart Left Panel (4) into Cart Bottom Panel Plate Assembly (1).
5. Repeat for Cart Right Panel (5).

A M6X12...6 PCS



B M6 SPRING WASHER...6 PCS



C M6 FLAT WASHER...6 PCS

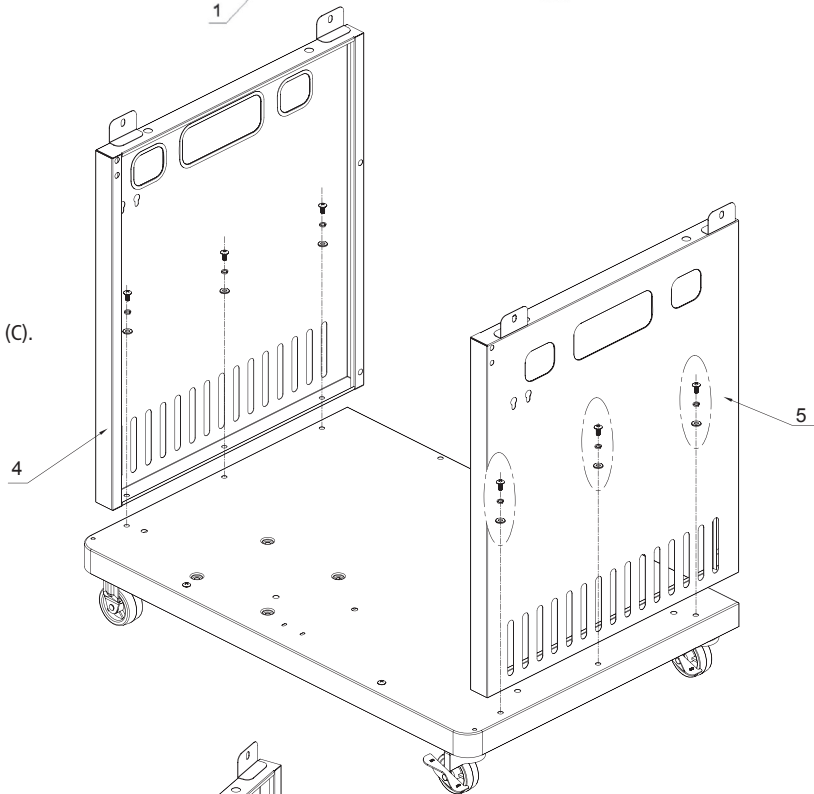

STEP 3

ATTACH CART REAR PANEL

1. Place Cart Rear Panel (6) between left and right panels aligning with pre-drilled holes.
2. Thread 4xBolt (A).
3. Screw 2xbolts through left-hand side of Cart Rear Panel (6) pre-drilled holes into Cart Left Panel (4), as shown in diagram.
4. Repeat for right-hand side of Cart Rear Panel (6).



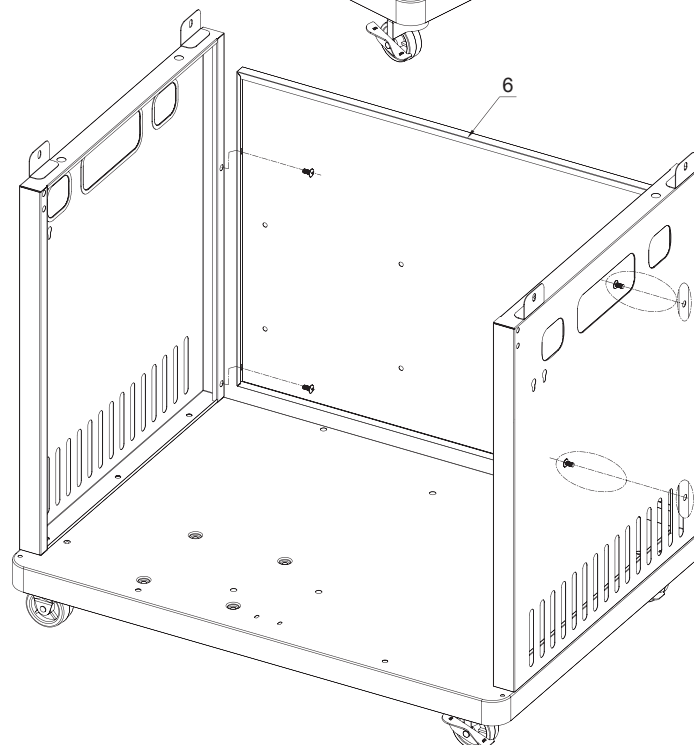

A M6X12...4 PCS



STEP 4

ATTACH GAS TANK TRAY AND MAGNET

1. Align Gas Tank Tray (7) pre-drilled holes to the right of Cart Bottom pre-drilled holes, as shown in diagram.
2. Thread 4xBolt (A) first with Spring Washer (B) and then Flat Washer (C).
3. Screw through Gas Tank Tray into Cart Bottom.
4. Align Magnet (8) to centre Cart Bottom Plate Assembly (1) pre-drilled holes, as shown in diagram.
5. Screw 2xBolt (K) through Magnet (8) and Cart Bottom Plate Assembly (1) into nut (L).

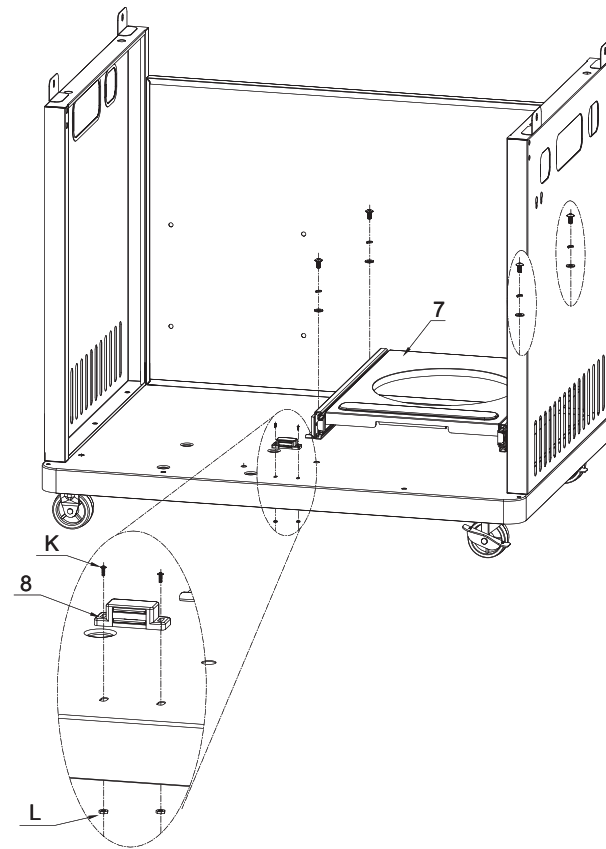

- | | | |
|---|--------------------------|-----------------------------------------------------------------------------------|
| A | M6X12...4 PCS |  |
| B | M6 SPRING WASHER...4 PCS |  |
| C | M6 FLAT WASHER...4 PCS |  |
| K | M3X10...2 PCS |  |
| L | M3 NUT...2 PCS |  |



STEP 5

ATTACH BASKET, BASKET VERTICAL AND HORIZONTAL SUPPORT

1. Align 2xBasket Horizontal Support (26) with pre-drilled Basket Vertical Support (25) side holes.
2. Thread 2xBolt (A) first with Spring Washer (B) and then Flat Washer (C).
3. Screw bolts through Basket Vertical Support (25) into Basket Horizontal Support (26) as shown in diagram.
4. Align Basket Vertical Support (25) to middle Cart Bottom Plate (1) pre-drilled hole.
5. Thread 1xBolt (A) first with Spring Washer (B) and then Flat Washer (C).
6. Screw bolt through Basket Vertical Support (25) bottom tab into Cart Bottom Plate (1).
7. Working from the back, align Basket Horizontal Support (26) with Cart Rear Panel (6) pre-drilled holes.
8. Thread 2xBolt (A) first with Spring Washer (B) and then Flat Washer (C).
9. Screw bolt through Cart Rear Panel (1) into Basket Horizontal Support (26) as shown in diagram (H View).
10. Repeat for left-hand side Basket Vertical Support (25) and remaining Basket Horizontal Support (26).
11. Insert both Baskets (9).

- | | | |
|---|---------------------------|-------------------------------------------------------------------------------------|
| A | M6X12...10 PCS |  |
| B | M6 SPRING WASHER...10 PCS |  |
| C | M6 FLAT WASHER...10 PCS |  |

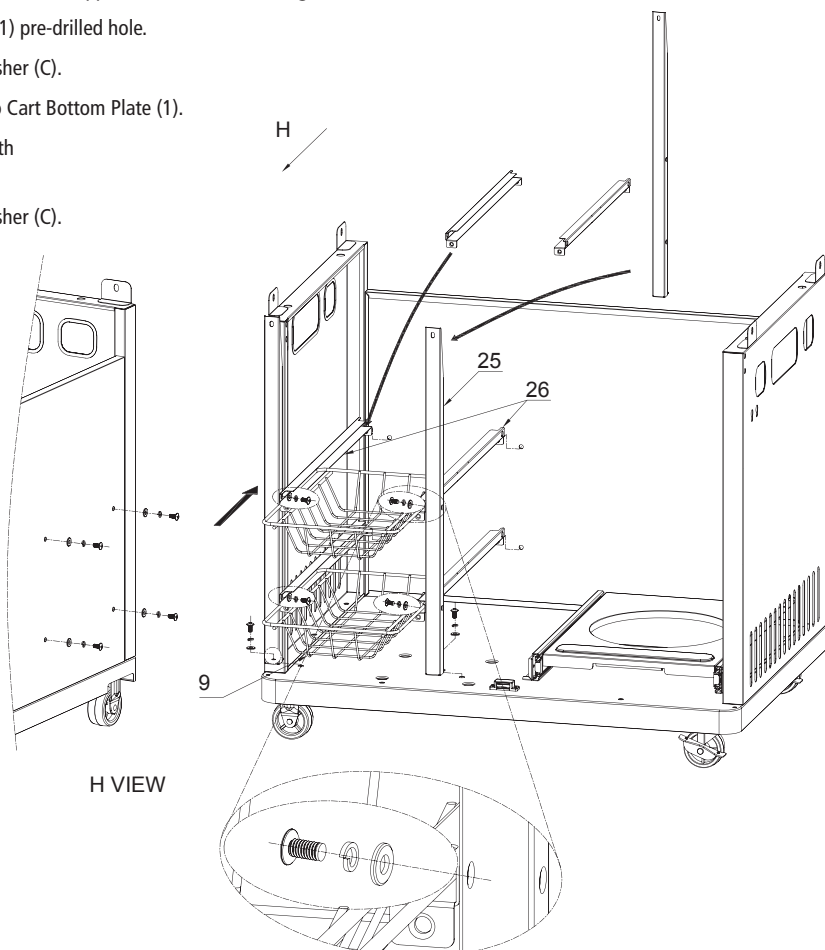

STEP 6

ATTACH DOOR AND DOOR UPPER

1. Align Door Upper (10) between top of left and right panels pre-drilled holes and in front of both Basket Vertical Support (25), as shown in diagram.
2. Thread 2xBolt (D) first with Spring Washer (B) and then Flat Washer (C) and lastly Left Top Door Bracket as shown in diagram.
3. Screw through Cart Left Panel (4) into Door Upper (10), as shown in diagram.
4. Repeat for right-hand side.
5. Align Basket Vertical Support (25) pre-drilled holes with Door Upper (10) holes.
6. Thread 2xBolt (A) first with Spring Washer (B) and then Flat Washer (C).
7. Screw bolt from inside cabinet through Basket Vertical Support (25) into Door Upper (10).
8. Repeat for second Basket Vertical Support (25). As shown in diagram (H View).
9. Install Door Assembly (11) by placing bottom door pin into one of the corner Cart Bottom Plate Assembly (1) pre-drilled hole, as shown in diagram.
10. Push down spring loaded pin on the top of door and place into Door Axis Support release pin.
11. Repeat for opposite door.
12. Door Assembly (11) should now be secure.

- A M6X12...2 PCS
- B M6 SPRING WASHER...6 PCS
- C M6 FLAT WASHER...6 PCS
- D M6X45...4 PCS

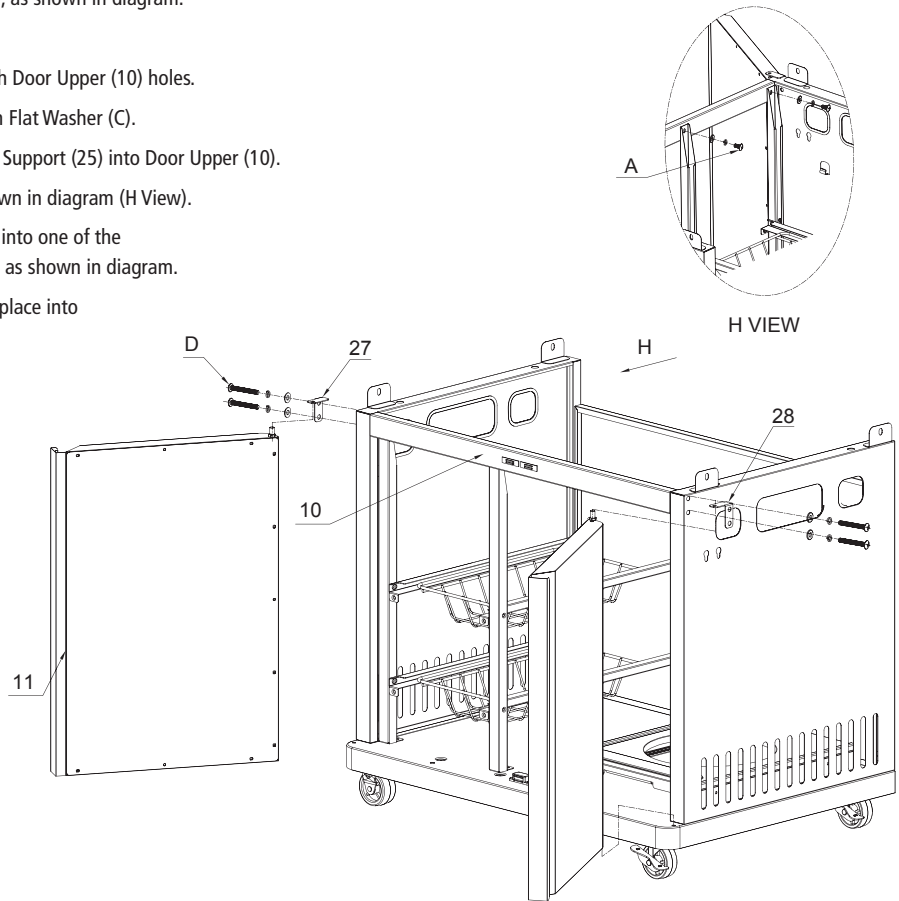

STEP 7

ATTACH BODY & LID ASSEMBLY

1. With the help of another person, lift the Body & Lid Assembly (12) and carefully rest on top of cabinet.
2. Align cabinet side brackets with Body & Lid Assembly (12).
3. Thread 4xBolt (A) first with Spring Washer (B) and then Flat Washer (C).
4. Screw bolts through cabinet right and left side panel brackets into Body & Lid Assembly (12) thread inserts as shown in diagram.

- A M6X12...4 PCS
- B M6 SPRING WASHER...4 PCS
- C M6 FLAT WASHER...4 PCS

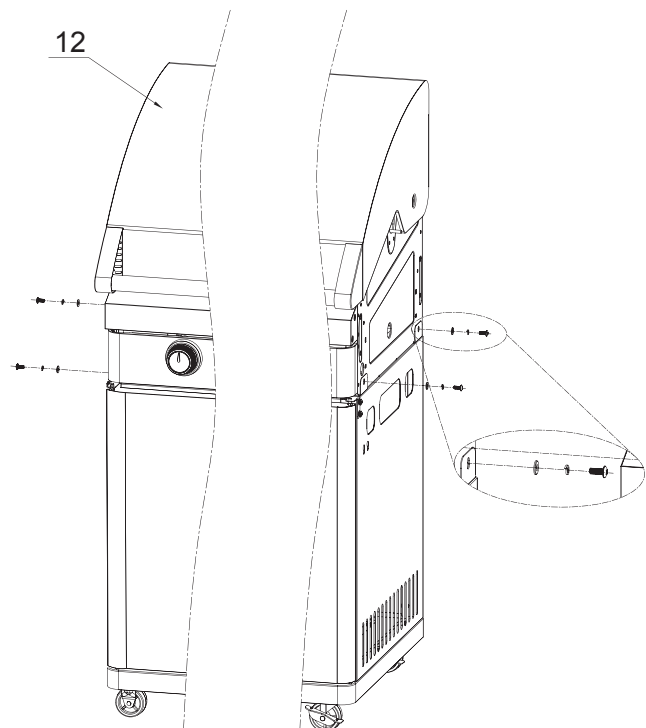

STEP 8

ATTACH LEFT SIDE SHELF TO BODY & LID ASSEMBLY

1. Thread 2xBolts (E) through Spring Washer (B), Flat Washer (C), rear side of shelf into 1xSide Spacer Rear (16).
2. Thread 2xBolts (E) through Spring Washer (B), Flat Washer (C), front side of shelf into 1xSide Spacer Front (15).
3. Align Left Shelf Assembly (13) with Body & Lid Assembly (12) thread inserts.
4. Partially screw top rear and front bolts making sure bottom bolts stay aligned. Partially screw bottom bolts.

ATTACH RIGHT SIDE SHELF TO FIREBOX ASSEMBLY

1. Repeat for Right Side Shelf (14).

B M6 SPRING WASHER...8 PCS

C M6 FLAT WASHER...8 PCS

E M6X25...8 PCS

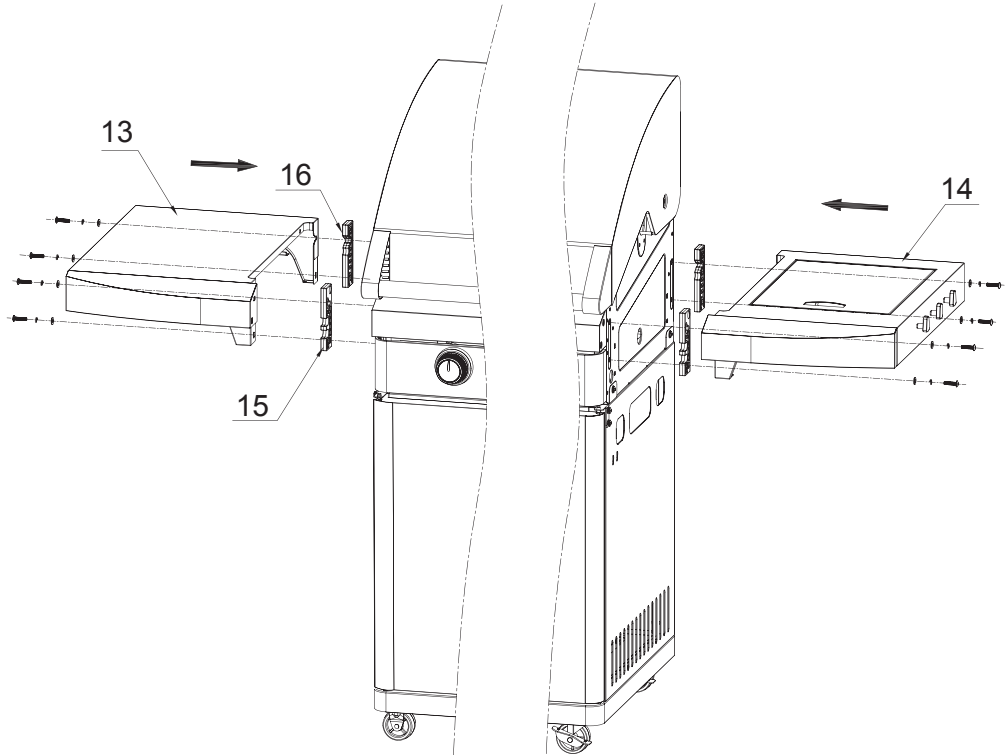

STEP 9

SECURE LEFT SIDE SHELF FASCIA TO BODY & LID ASSEMBLY FASCIA

1. Align Left Side Shelf (13) fascia panel pre-drilled holes to Body & Lid Assembly (12) fascia panel.
2. Thread 2xBolts (A) through Spring Washer (B), Flat Washer (C).
3. Screw bolts through both fascias as shown in diagram.
4. Go back and tighten all six bolts for Left Side Shelf.

SECURE LEFT SIDE SHELF FASCIA TO BODY & LID ASSEMBLY FASCIA

1. Repeat for Right Side Shelf (14) fascia.

A M6X12...4 PCS

B M6 SPRING WASHER...4 PCS

C M6 FLAT WASHER...4 PCS

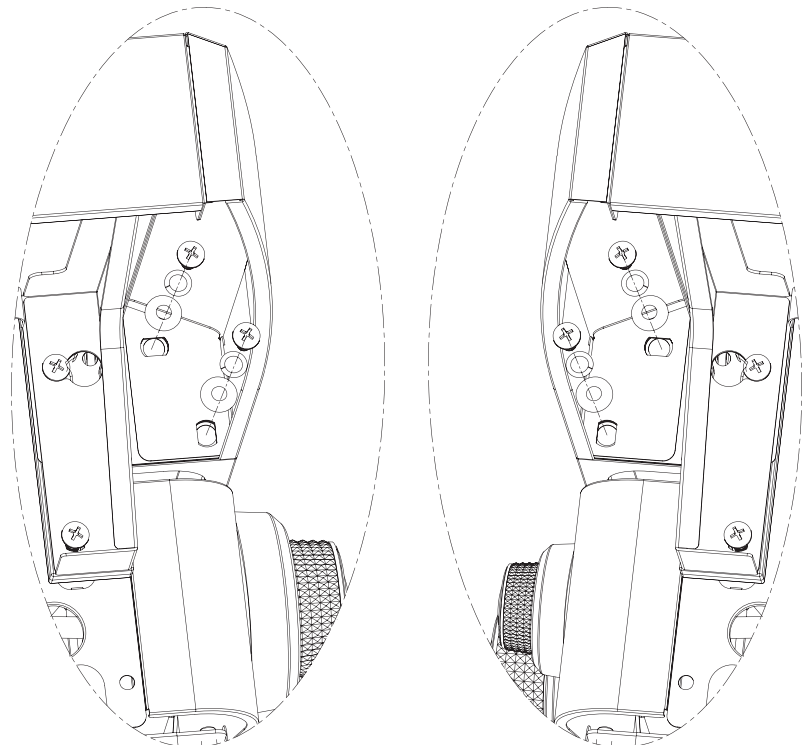





STEP 10

PLACEMENT OF SIDE BURNER ASSEMBLY AND SIDE GRILL

1. Thread side burner hose through hole in right-side Body & Lid Assembly (12) and place behind side burner fascia as shown in diagram.
 2. Unscrew side burner hose nut and place valve nozzle end of hose through side burner bracket as shown in diagram (H View).
 3. Secure in bracket with side burner hose nut, as shown in diagram (H View).
- NOTE: THIS IS A LEFT-HAND THREAD MEANING IT TIGHTENS IN AN ANTI-CLOCKWISE DIRECTION.

4. Open the Right Side Shelf Assembly (14) lid and tilt the Side Burner Assembly (18) pipe through base burner hole on to the valve nozzle, as shown in diagram.
5. Ensure the valve nozzle enters into the burner pipe.
6. Plug ignition wire into electrode.
7. Thread 4xBolt (F) first with Mica Washer (I).
8. Screw down through Side Burner Assembly (18) into Right Side Shelf Assembly (14) and secure each bolt (F) with Flat Washer (H), Spring Washer (G) and then Nut (J) as shown in diagram.
9. Position the Side Grill (17) over Side Burner Assembly (18).

- | | | |
|---|--------------------------|-------------------------------------------------------------------------------------|
| F | M4X10...4 PCS |  |
| G | M4 SPRING WASHER...4 PCS |  |
| H | M4 FLAT WASHER...4 PCS |  |
| I | M4 MICA WASHER...4 PCS |  |
| J | M4 NUT...4 PCS |  |

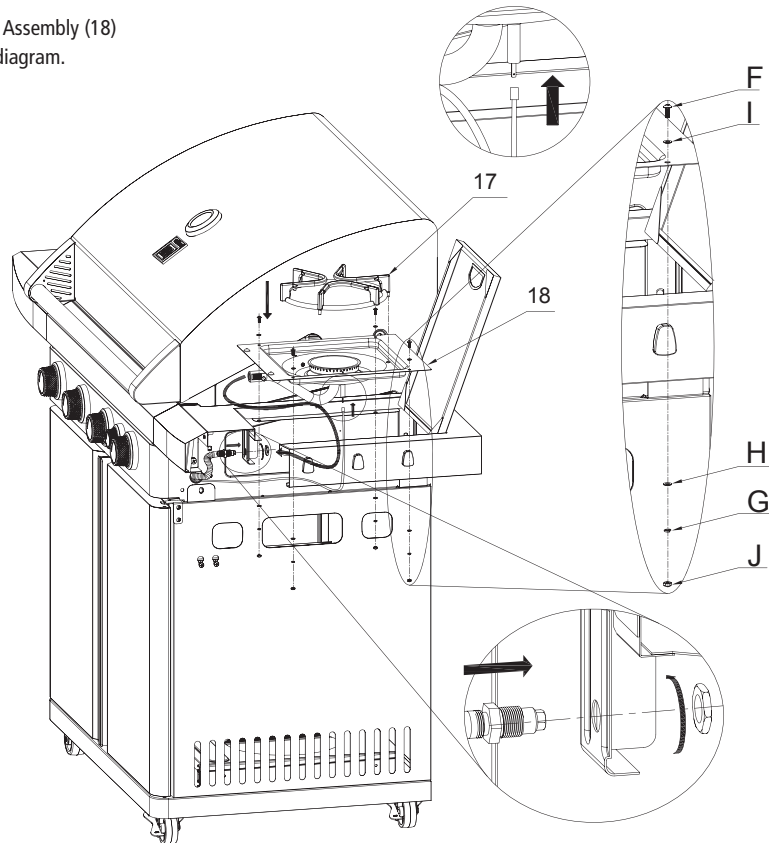

H VIEW

STEP 11

PLACEMENT OF WARMING RACK, COOKING GRID AND PLATE

1. Place 2 x Heat Panel (22) over the 2 x right-hand side burners.
2. Cooking Grid (20) to be placed directly over the right-hand side burners and both Heat Panels (22), resting on inside body ledge.
3. Place Cooking Plate (21) over both left-hand side burners, resting on inside body ledge.
4. Insert Warming Rack (19), place back feet into holes in back body vent panel and rest the front feet on the side body panel. As shown in diagram.

THE ABOVE COOKING SURFACE CONFIGURATION IS HIGHLY RECOMMENDED. ANY ALTERATION CAN BE POTENTIALLY DANGEROUS AND WILL VOID YOUR WARRANTY.

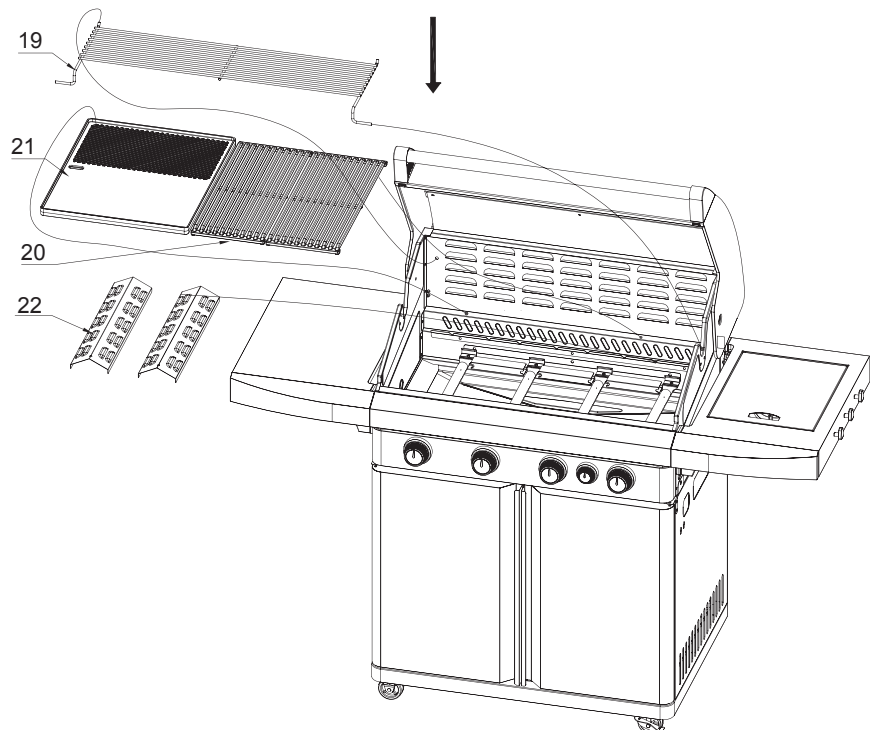

STEP 12

PLACEMENT OF OIL CUP

1. Working from the back, slide Oil Cup (23) into the brackets under the Fat Tray, as shown in diagram.

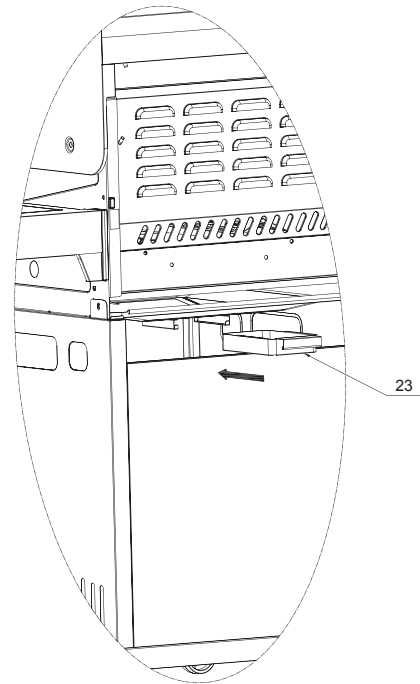

STEP 13

ATTACH FLEXIBLE GAS HOSE FIXED AND CONNECT GAS CYLINDER

1. Prior to fitting gas cylinder ensure the cart, shelves, body and lid are secure.
2. All fixings are tight.
3. Partially loosen bolts in Flexible Gas Hose Fixed (24) and position over main barbeque gas hose connection as shown in diagram (H View).
4. Place bolt heads through mounting holes in Cart Right Panel (5) and push down into correct position as shown in H View. Tighten bolts but do not over-tighten.
5. Place gas cylinder on Gas Tank Tray; ensure the gas supply is off.
6. Connect the regulator to the gas cylinder;
THIS IS A LEFT HAND THREAD MEANING IT TIGHTENS IN AN ANTI-CLOCKWISE DIRECTION.
7. Care must be taken not to cross-thread these connections and do not over-tighten the nut.

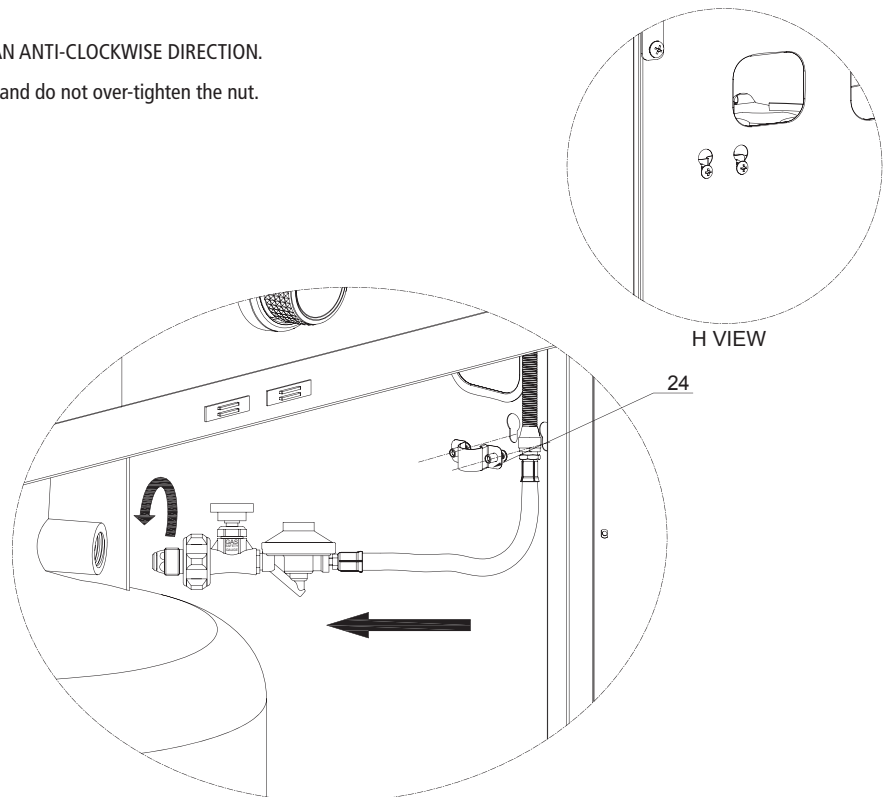

IMPORTANT HEALTH & SAFETY INFORMATION

1. WARNING

FOR OUTDOOR USE ONLY! DO NOT USE INDOORS

- Please read these instructions carefully prior to assembly and use.
- Failure to follow these instructions could lead to serious injury and/or significant damage to property.
- Do not start the barbeque if there is any doubt over the correct assembly, ignition, gas control or cooking of the unit.
- These instructions should be retained for future reference.
- For use with ULPG cylinder gas only.
- The barbeque must have a minimum side clearance from any combustible material of at least 250mm. Additionally there must be a clearance of at least 1500mm above the cooking surface of the barbeque, 500mm clearance at the back.
- Flammable materials and liquids must be stored well away from the barbeque.
- Aerosols must not be used near the barbeque.
- The barbeque should not be moved when lit or hot.
- A lit barbeque should be attended at all times.
- Gas cylinders MUST be stored vertically.
- Avoid dousing the barbeque with water.
- Turn off the gas cylinder when the barbeque is not in use.
- Always allow the barbeque to completely cool down before covering.
- For safety reasons it is advisable to keep a fire extinguisher and fire blanket close to hand.
- Unsupervised children, elderly and infirm should not be allowed close to the barbeque during pre-heat, cooking, burn off or cooling down of the unit.
- Please dispose of all polythene packing and plastic bags carefully and keep out of the reach of children.



2. GAS TYPE AND REGULATOR

- This barbeque is only designed to run off ULPG cylinder gas.
- To ensure maximum performance a gas cylinder of 9kg is recommended.
- The regulator as supplied should be firmly tightened but care must be taken not to over-tighten the connections.
- The regulator as supplied is the correct regulator for this item.
- Do not attempt to connect gas to a barbeque that is not secure in a frame or trolley.
- To ensure performance a gas cylinder of minimum 4.5kg is required.

3. IF YOU SMELL GAS

DO NOT ATTEMPT TO OPERATE THE BARBEQUE UNTIL THE CAUSE OF THE GAS SMELL HAS BEEN IDENTIFIED AND ELIMINATED

- Immediately isolate the gas supply by turning the gas off at the cylinder.
- Extinguish all naked flames.
- Do not operate any electrical devices close to the barbeque.
- Check for leaks as described further in this manual.
- Ensure that local area is well ventilated to remove any excess gas.
- If the gas smell continues the barbeque should not be operated under any circumstances and it is important to make immediate contact with the customer service centre.

4. PRECAUTIONS

BEFORE FIRST TIME OPERATION AND AFTER EACH CYLINDER EXCHANGE/REFILL ALL CONNECTIONS SHOULD BE CHECKED FOR GAS LEAKS

- Connections can be checked for leaks by using a soapy water solution.
- Naked flames (matches or other open flames) must not be used to check for gas leaks, this is a dangerous practice to be avoided.
- Flammable liquids of any description, including petrol, lighter fluid, oils, etc must not be stored close to the barbeque.
- Spare or extra gas cylinders must NOT be stored within close proximity of this barbeque or any other gas or electric appliance.
- Spare or extra gas cylinders should not be stored where they are exposed to continuous direct sunlight, as this is a potentially dangerous practice.
- The position of the assembled barbeque should be such that the gas cylinder is not left exposed to direct sunlight as this is a potentially dangerous situation.
- Please read and follow all instructions in this manual, if in doubt as to any operational or safety precaution contact the customer service centre.
- Please ensure the gas cylinder is positioned outside of the barbeque frame. It must not be positioned underneath the barbeque.
- For storage and cylinder exchange, disconnect the cylinder only. Do not disconnect hose from the appliance.

LEAK TEST

To test for leaks, turn on the gas bottle valve and apply soap suds to the areas shown. Watch carefully for any signs of bubbling, which indicate a gas leak.

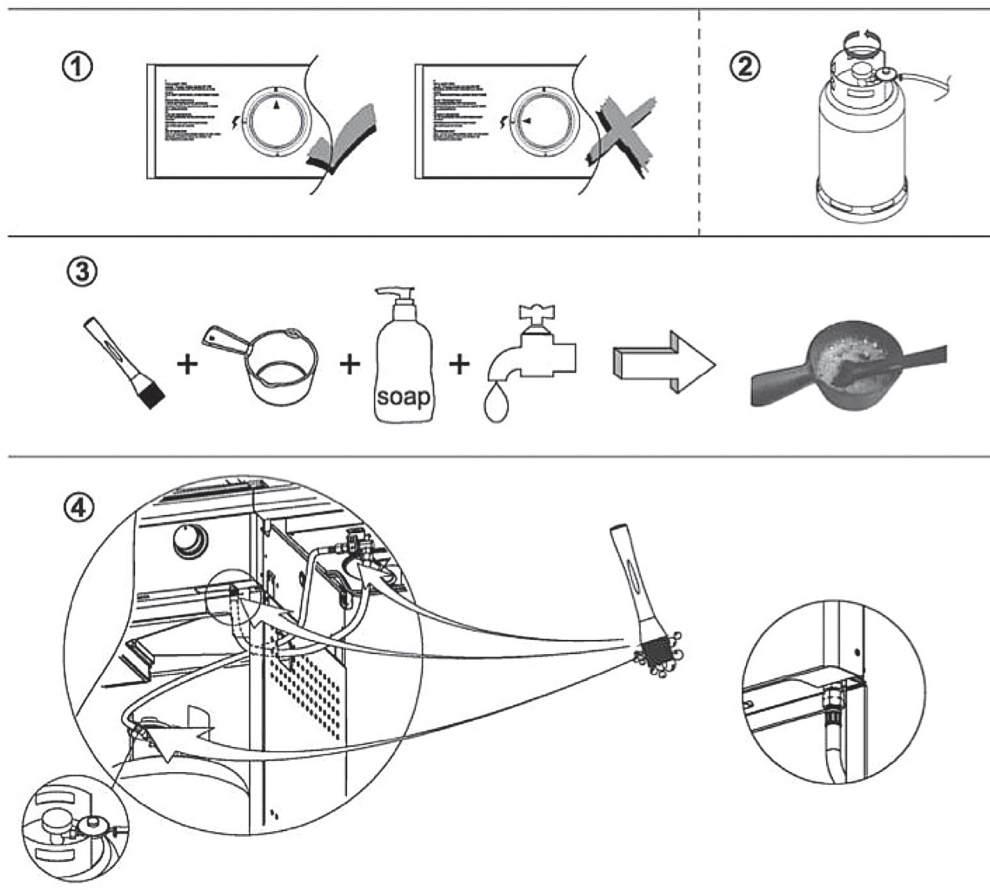

WARNING

- The design of the barbecue is with one solid hotplate only. More than one solid hotplate will create a dangerous situation where the barbecue can overheat.
- Remove all transit protection before using the barbecue

 <p>Gas Safety Certified</p> <p>SAI GLOBAL GSCS20247</p>	Model	-	BGW4YA036A
	Gas Type	-	UNIVERSAL LPG
	Burner Injector Size	-	0.94mm
	Burner Gas Consumption	-	12MJ/Hr
	Burner Gas Pressure	-	2.75Kpa
	Side Burner Injector Size	-	1.02mm
	Side Burner Gas Consumption	-	13.5MJ/Hr
	Side Burner Gas Pressure	-	2.75Kpa
	Total Gas Consumption	-	61.5MJHr
<p>Air is admitted from the ventilation holes at the base and side of the firebox and also around the slot holes at the grill plate when hood is open. When the hood is closed, air is also admitted out from the ventilation holes at the back between the barbecue hood and firebox. Please ensure all these locations are not blocked by anything.</p>			

IGNITING

CONNECT GAS BOTTLE:

Use only an approved LPG tank. Check the tank for rust and other signs of corrosion. Check the hose and valve condition with each gas bottle change. Tightly screw the hose fitting into the tank outlet nozzle (remembering that this screws in anti-clockwise). To check for gas leaks, apply soap suds to all gas joints and check for bubbling that will indicate escaping gas. If you smell gas, but no leak can be found, don't operate the barbecue. Contact an authorised technician.

IGNITE BURNERS:

Turn on the valve on top of the gas tank – anti-clockwise. Turn on each burner one at a time. Be sure that each burner has ignited. If a burner has failed to ignite, turn it off and try again. Do not leave all burners on high (and the lid closed) for more than ten minutes unless actually cooking.

CLEANING AND REPAIR:

Other than general cleaning, all work must be carried out by authorised technicians.

WARNING: THE SIDE BURNER MUST ALWAYS BE LEFT OPEN DURING COOKING AND MUST NOT BE USED TO EXTINGUISH THE BURNER.

LIGHTING THE SIDE BURNER:

- The lid must be opened prior to ignition of the burner.
- Turn control knob to "OFF".
- Check that the gas supply is turned on at the gas cylinder.
- Push and turn the side burner control knob to "HIGH", this will light the burner in the same manner as the main burners.
- If burner does not ignite, repeat the ignition process for up to 5 times to ignite the burner.

MANUAL IGNITION:

To light the barbecue manually, slide the fat tray out half way from the back of the barbecue. From underneath the right or left severy place a 90mm long lit match next to the burner via the hole located on the side of the firebox and turn the burner to "HI" position.

COOKING

BEFORE THE FIRST USE:

Before igniting for the first time, you should wipe the cooking surfaces with a damp cloth to remove any manufacturing or shipping dust. You should then cure or season the cooking surfaces. To do this, brush with a light coating of cooking oil, turn on all burners to LOW and leave for half an hour. Avoid cooking in strong winds as this can adversely affect cooking efficiency – and could cause the flames to extinguish. Allow food to be cooked to come to room temperature by removing from the fridge an hour before cooking.

GRILLING:

Open-lidded, open flame grilling is probably the most popular way of cooking on a barbecue. Beef steaks, chops and sausages; lamb back straps and cutlets; chicken breasts, thigh cutlets and Marylands; pork cutlets, chops and loin fillets; satays and other skewered meats all love the barbecue; whole fish, prawns and bugs. Many vegetables also respond to grilling. Corn on the cob, eggplant, capsicum, zucchini, asparagus and fennel are just a few that grill beautifully. For steaks, chops, fillets and sausages, a medium-high heat is best. Oil the grill ribs before cooking, using an oil with a high smoke point (canola, sunflower or safflower). Except for sausages, also oil the meat lightly and season with salt and pepper before cooking. Resist the temptation to turn meat too soon and too often. The higher the heat, the more easily you can produce restaurant-quality steaks with nicely charred outsides, but moist pink flesh inside. **GRILLING TIPS:** Remember to preheat the grill before you start cooking. And don't serve the meat straight away, but allow to rest for 10 minutes. This helps the meat to reabsorb the juices before being cut.

ROASTING:

Barbecues are increasingly being used for closed roasting. You can cook whole chickens, legs and shoulders of lamb, whole pork necks and ribs, whole fish and standing rib roasts. They all respond magnificently to slow roasting in a barbecue. Roasting is usually done between 130°C and 180°C and can take less than an hour (for a fish) to six hours or more (American-style pork ribs). **ROASTING TIPS:** Don't use all burners when roasting. Use the outer burners and place the food to be roasted in the middle so that it cooks by ambient heat, not direct flame.

TEPPANYAKI COOKING:

Cooking on a solid plate (teppanyaki plate) is growing in popularity. Traditionally a barbecue's solid plate has been used to cook onions, bacon or eggs, but nowadays it is being used more and more to cook foods as diverse as fish fillets, scallops, duck breasts, Asian vegetables and even fried rice.

TEPPANYAKI TIPS:

Keep a small bottle of light cooking oil handy, as food will stick if the surface isn't kept well oiled.

WOK COOKING:

Wok cooking is fast, easy and increasingly popular in Australian homes. The great advantage of having a wok burner on your Wiltshire BAR-B barbecue is that you can do several types of cook at the one time. As well as stir fries, if you have a lid for your wok, you can use the wok burner to cook many Asian vegetables that need to be partially steamed. **WOK TIPS:** In Asia, woks are used over ferociously high heat. Use the burner's full heat, but be prepared to move the cooking food around the wok constantly so that it cooks evenly and doesn't burn. If using a steel wok don't clean it with soap, but use hot water and a sponge. Soap destroys the oil that seasons the wok. Thoroughly dry and wipe on a thin film of oil before storing.

RECIPES

For barbecuing ideas, visit the Wiltshire BAR-B website www.wiltshirebbq.com.au

CLEANING

Your Wiltshire BAR-B barbecue is built from quality components that will give you many years of reliable use.

There are a few basic cleaning and maintenance procedures that will ensure it keeps working at its best.

REGULAR CLEANING:

Get in the habit of a regular cleaning regime. Before each use, clean the fat drip tray. Clean the cooking surfaces regularly to prevent fat build-up and possible fat fires. Clean the exterior of the barbecue with warm soapy water. A wipe with a standard window cleaner or spraying with WD40 also works well. If you have bought a cover, we don't recommend stainless steel wipes as these leave an oily residue.

MAINTENANCE

There are a couple of maintenance procedures that you should carry out at least once a year.

BURNER: Once a year, remove the burner and inspect it for any signs of blockage. If necessary, clear any obstructions with compressed air or short piece of stiff wire. Remove any rust and dirt with a wire brush. Replace the burner.

GAS SUPPLY: Inspect the gas hose and fittings for signs of deterioration and replace if necessary. Test the entire gas delivery system for leaks using the technique described in 'IGNITING'.

CART: Do a quick check of all the screws and retighten if necessary.

CAST IRON PLATE: Regularly season the plate. To prevent rust lightly spray with canola oil.

TROUBLE SHOOTING

PROBLEM	POSSIBLE CAUSE	ACTION
Strong gas smell	Faulty connections Deteriorated hose	Turn off & check all Connections Check thoroughly
Gas won't ignite	Gas bottle empty Burner blocked Heat panels askew	Check & replace Check & clean Ensure heat panels have not moved
Gas goes out	Wind	Find more sheltered spot
Uncontrolled fire	Fat build-up Obstruction	Clean heat panels & cooking plates Check burner & clean

If, when assembling your barbecue, you discover a missing part or parts, identify the parts number and your product's serial number (located on the rating label on the side of the firebox) and contact McPhersons Consumer Products. You can do this on our website www.wiltshirebbq.com.au or by calling 1800 651 146 (Australia) or 0800 182 022 (New Zealand).

ACCESSORIES

Wiltshire BAR-B products provide you with all of the tools to become a master of the BBQ!



BAR-B Foil Trays

5 pack of 15.5 x 22cm foil trays that are perfect for fat collection under the BBQ, baking vegetables or roasting small cuts of meat. A free roast vegetable medley recipe is included!



BAR-B Pizza Stone Set

Set contains 33cm pizza stone with rack and cutter. Pizza stone is made of cordierite which is made specifically to withstand higher temperatures on the BBQ. Pizza cutter cuts through pizza easily and quickly.



BAR-B Steak Mates

Take the worry out of producing a perfectly cooked steak with the new Wiltshire BAR-B Steak Mates. Just insert one of these small, reusable mini thermometers into the side of your steak and it will indicate when your meat is rare, medium or well-done. For the perfect steak, this product will become your best mate.



BAR-B Wipes

For a sparkling BBQ, use the Wiltshire BAR-B Wipes. Available in a super convenient pack of 10, these heavy duty wipes easily remove food build-up and grease. The small nodules allow for scrubbing without scratching your BBQ. Use on any part of your BBQ, accessories or public BBQs.



BAR-B-TONG

Your favourite kitchen tongs are now available for your BBQ! With long handles and effective locking devices, these tongs are great for taking on picnics, serving and cooking on the BBQ.



BAR-B-MATE

Australia's first multi-purpose tool designed specifically for the BBQ! The Bar B Mate lifts, serves, slices, and scrapes with a straight cutting edge and prongs for piercing sausages.

WARRANTY

YOUR WILTSHIRE BAR-B BARBECUE IS COVERED BY A MANUFACTURERS WARRANTY FOR 2 YEARS FROM THE DATE OF PURCHASE.

Please keep your purchase receipt in a safe place. It is also a good idea to note the serial number (located on the rating label on the side of the firebox) on your receipt.

Thankyou for purchasing one of our quality Wiltshire BAR-B BBQs.

YOUR WILTSHIRE BAR-B BBQ IS COVERED AGAINST DEFECTS FOR A PERIOD OF 2 YEARS FOR PARTS AND LABOUR, REPAIR OR REPLACEMENT.

THIS WARRANTY EXCLUDES SURFACE RUST AND DAMAGE CAUSED BY ABUSE OR NEGLIGENCE.

The warranty for Australia is given by McPherson's Consumer Products Pty Ltd
105 Vanessa Street, Kingsgrove, NSW 2208.

The warranty for New Zealand is given by McPherson's Consumer Products (NZ) Limited
30 Highbrook Drive, East Tamaki, Auckland 2013.

Any claim under this warranty must be made within 2 years of the date of purchase of the product. Proof of purchase must be presented.

For Australian Customers

To make a claim under the warranty please contact:

Australia - 1800 651 146

This warranty is provided in addition to the other rights and remedies you may have under law: our goods come with guarantees that cannot be excluded under Australian Consumer Law. You are entitled to a replacement or refund for a major failure and compensation for any other reasonably foreseeable loss or damage. You are also entitled to have the goods repaired or replaced if the goods fail to be of acceptable quality and the failure does not amount to a major failure.

For New Zealand Customers

To make a claim under the warranty please contact:

New Zealand - 0800 182 022

To make a claim under the warranty please contact the store where the barbecue was purchased.

This warranty is provided in addition to the other rights and remedies of the Consumer Guarantees act 1993.

Goods presented for repair may be replaced by refurbished goods of the same type rather than being repaired. Refurbished parts may be used to repair the goods.

Please thoroughly read conditions of warranty.

CONDITIONS OF THE WARRANTY

- The appliance must be operated and maintained in accordance with the instructions supplied in the operating manual.
- Any repair does not extend the warranty period.
- Use of any parts other than original Wiltshire BAR-B parts will void this warranty.

INSTALLATION CONDITIONS

- All installations must conform to the applicable Gas, Electrical and Building standards as laid down by the local codes for the state or region.
- If the appliance is changed to natural gas (if applicable). It must be converted and installed by a licensed gas fitter.

WHAT IS NOT COVERED IN THE WARRANTY

- Removal or re-installation costs. This warranty does not cover costs for transit, nor in home service.
- Liability will only be accepted for loss or damage during transit if at the time the product was being transported by Wiltshire BAR-B or a Wiltshire BAR-B approved contractor.
- Lack of maintenance, abuse, neglect, misuse, accidental or improper installation of this appliance.
- Scratches, dents, corrosion or discolouration caused by heat, abrasive chemical cleaners or chipping of porcelain enamel parts.
- Corrosion or damage caused by exposure to the elements such as insects, weather, hail or grease and fat fires.
- Rusting of cast iron plates, grills and burners.
- Cleaning and wear and tear; service calls of this nature are chargeable.
- Commercial use of the product.
- Unauthorized repairs or modifications during the warranty period.
- Glass breakage due to misuse or overheating.
- Consumable items, example - batteries.

RECORD THE FOLLOWING INFORMATION

Attach the copy of the purchase receipt here:

Date of Purchase.....

Purchased From.....

Location.....

Model Name and Number.....

Serial Number.....

Receipt Number.....

Note: The serial number is located on the rating label on the side of the firebox.

FOR TECHNICAL ASSISTANCE

For Australian customers

If you experience any technical issues with your Wiltshire BAR-B BBQ, in the first instance review the instruction manual or contact the warranty service agent below.

For New Zealand customers

If you experience any technical issues with your Wiltshire BAR-B BBQ, in the first instance review the instruction manual or contact the warranty service agent below.

FOR WARRANTY CLAIMS AND SPARE PARTS

Australian customers

McPherson's Consumer Products Pty Ltd
105 Vanessa Street, Kingsgrove, NSW 2208.

New Zealand customers

McPherson's Consumer Products (NZ) Limited
30 Highbrook Drive, East Tamaki, Auckland 2013.

wiltshire®



CONTACT US

Wiltshire is a brand of McPhersons Consumer Products.

Australia: 105 Vanessa St, Kingsgrove, NSW 2208.

New Zealand: 30 Highbrook Drive, East Tamaki, Auckland 2013.

Singapore: 20 Toh Guan Road, #03-00 CJ GLS Building, Singapore 608839

www.wiltshirebbq.com.au